

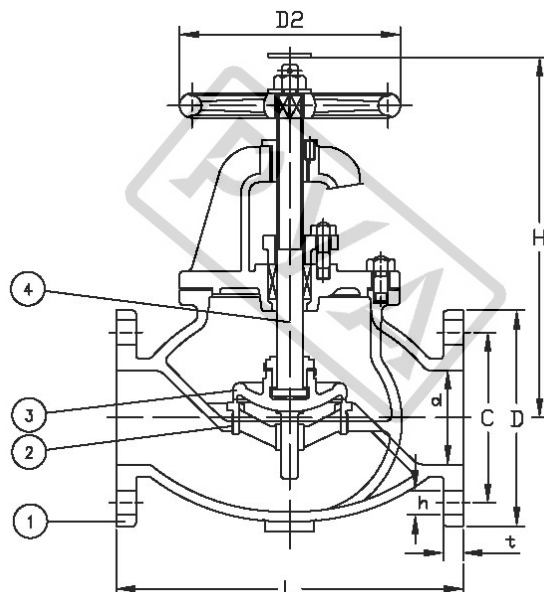

# JISF7309 16K CAST IRON GLOBE VALVE



Pressure Test MPa			
Nominal Pressure/PN	1.6MPa	Shell Test	3.2 MPa
		Seat Test	2.4 MPa

Main material for fittings			
Item	Fittings	Material	Mark
1	Body	Cast Iron	FC200
2	Bonnet	Cast Iron	FC200
3	Disc	Stainless Steel/Cast Bronze	SS420/BC6
4	Seat	Stainless Steel/Cast Bronze	SS420/BC6
5	Stem	Stainless Steel/Forged Brass	SS400/C3771BD
6	Handwheel	Cast Iron	FC200

Main data for flange connection						
Model	Face To Face	Flange Diameter	Flange PCD	Flange Hole	Height	Weight
	L	D	C	n* $\phi$ h	H	kgs
F7309 16K50	220	155	120	8 $\times$ $\phi$ 19	285	19.6
F7309 16K65	270	175	140	8 $\times$ $\phi$ 19	310	28.3
F7309 16K80	300	200	160	8 $\times$ $\phi$ 23	340	40.4
F7309 16K100	350	225	185	8 $\times$ $\phi$ 23	385	56.9
F7309 16K125	430	270	225	8 $\times$ $\phi$ 25	455	89.5
F7309 16K150	500	305	260	12 $\times$ $\phi$ 25	510	123.0
F7309 16K200	570	350	305	12 $\times$ $\phi$ 25	630	188.0

Design	Check	Signature	Logo	Supplier
asbsey	Chrit	Figor		PROMET VALVES AUSTRALIA
JAN.01,2013	JAN.01,2013	JAN.01,2013		

## PROMET VALVES AUSTRALIA

1A Green Road Woodville West SA 5011 Australia / Tel:+61 8 8268 1777 / Fax:+61 8 8268 1711  
 promet@prometvalves.com / www.prometvalves.com / ABN47 096 425 697